

## Pain Management through IoT Controlled Superficial Heating Modalities (SHM), Transcutaneous Electrical Nerve Stimulation (TENS) and Vibration Therapy

Samir Sharma<sup>1</sup>, Atreyee Sharma<sup>2</sup>, Utpal Kumar Paul<sup>3</sup>, Debashis Roy<sup>4</sup>,  
Amar Prakash Sinha<sup>5</sup>

<sup>1,3,5</sup>Dept. of Ece, Bit Sindri, Jharkhand, India

<sup>2</sup>Dept. of Physiotherapy, Mmdu, Mullana, Ambala, India

<sup>4</sup>Dept of Ece, Silli Polytechnic, Ranchi, India

Corresponding Author: **Samir Sharma**

**Abstract:** Magnetic therapy utilizing Pulsed Electro Magnetic Field (PEMF) and Transcutaneous Electrical Nerve Stimulation (TENS) has emerged as a promising non-invasive neuromodulating therapy for the treatment of various chronic pain syndromes. This paper highlights the effectiveness of PEMF and TENS in providing pain relief, as reported by numerous patients. Researchers have been investigating the impact of electric and magnetic fields on biological tissues to better understand the mechanisms underlying these therapies [1][2]. The efficacy of TENS is influenced by several factors, including the specific condition being treated, the placement of electrodes on the skin, and the settings of the TENS unit such as pulse frequency, duration, and intensity [3][4]. However, despite the widespread use of TENS, there remains a need for further evaluation of its effectiveness, particularly in assessing parameters such as stiffness and lack of mobilization [5][6]. Future studies should aim to comprehensively explore these factors to enhance our understanding of TENS efficacy and optimize its therapeutic outcomes for chronic pain management [7]. Superficial Heating Modalities (SHM) represent valuable therapeutic tools in the management of musculoskeletal conditions and pain syndromes [8][9]. Whether applied superficially or deeply, heat therapy can effectively alleviate pain, improve flexibility, and enhance tissue healing [10][11]. By understanding the mechanisms of action and clinical applications of different heating modalities, healthcare professionals can optimize their use to promote patient comfort and recovery [12][13]. The 50 Hz vibration in physiotherapy kits enhances muscle function, circulation, and healing [14][15]. The device generates 50 cycles per second, stimulating muscle spindles, leading to a tonic vibration reflex (TVR) that improves muscle tone and strength by repeated contractions [16][17]. It increases neural activity, improving neuromuscular pathways, muscle coordination, and control, beneficial for rehabilitation and training [18]. Enhanced blood flow and lymphatic circulation from vibrations aid in faster recovery and reduced soreness by dilating blood vessels [19]. It also modulates pain by stimulating large-diameter afferent nerve fibers, inhibiting pain signal transmission through the spinal cord, reducing pain sensation in treated areas [20].

**Keywords:** Pulsed Electro Magnetic Field (PEMF), Transcutaneous Electrical Nerve Stimulation (TENS), Superficial Heating Modalities (SHM), Ultra Sound Therapy (UST).

**Introduction:** Magnetic therapy using Pulsed Electro Magnetic Field (PEMF) has been approved by the Food and Drug Administration (FDA) for specific conditions, including treatment of fractures that do not heal with standard medical treatment and

post-operative pain and edema in superficial soft tissues [21]. For severe migraines, depression, and obsessive-compulsive disorder, the US FDA has approved a specific type of magnetic therapy known as transcranial magnetic stimulation, which uses magnetic fields to stimulate brain cells [22]. It has also been observed that electromagnetic therapy is used along with other physical therapies such as Superficial Heating Modalities (SHM), Ultra Sound Therapy (UST), or Transcutaneous Electric Nerve Stimulation (TENS) [23][24]. The use of FDA-approved PEMF and TENS therapy for the above-mentioned conditions is equally considered with conventional medicine [25]. Magnetotherapy in its modern form emerged shortly after World War II, introducing magnetic and electromagnetic fields generated by diverse waveforms of supplying currents. Originating in Japan, this therapeutic approach swiftly spread to Europe, initially in Romania and the former Soviet Union [25]. Between 1960 and 1985, virtually all European nations developed and produced their magnetotherapeutic systems. The integration of PEMF, TENS, hot packs, and therapeutic ultrasound for pain management is the objective of the research. Blood contains a high percentage of iron due to the presence of hemoglobin; its magnetic properties are also subject to oxygenation levels. For example, venous blood has a stronger paramagnetic property than arterial blood [26]. The adjacent Figure 1 shows the schematic diagram of the proposed model.

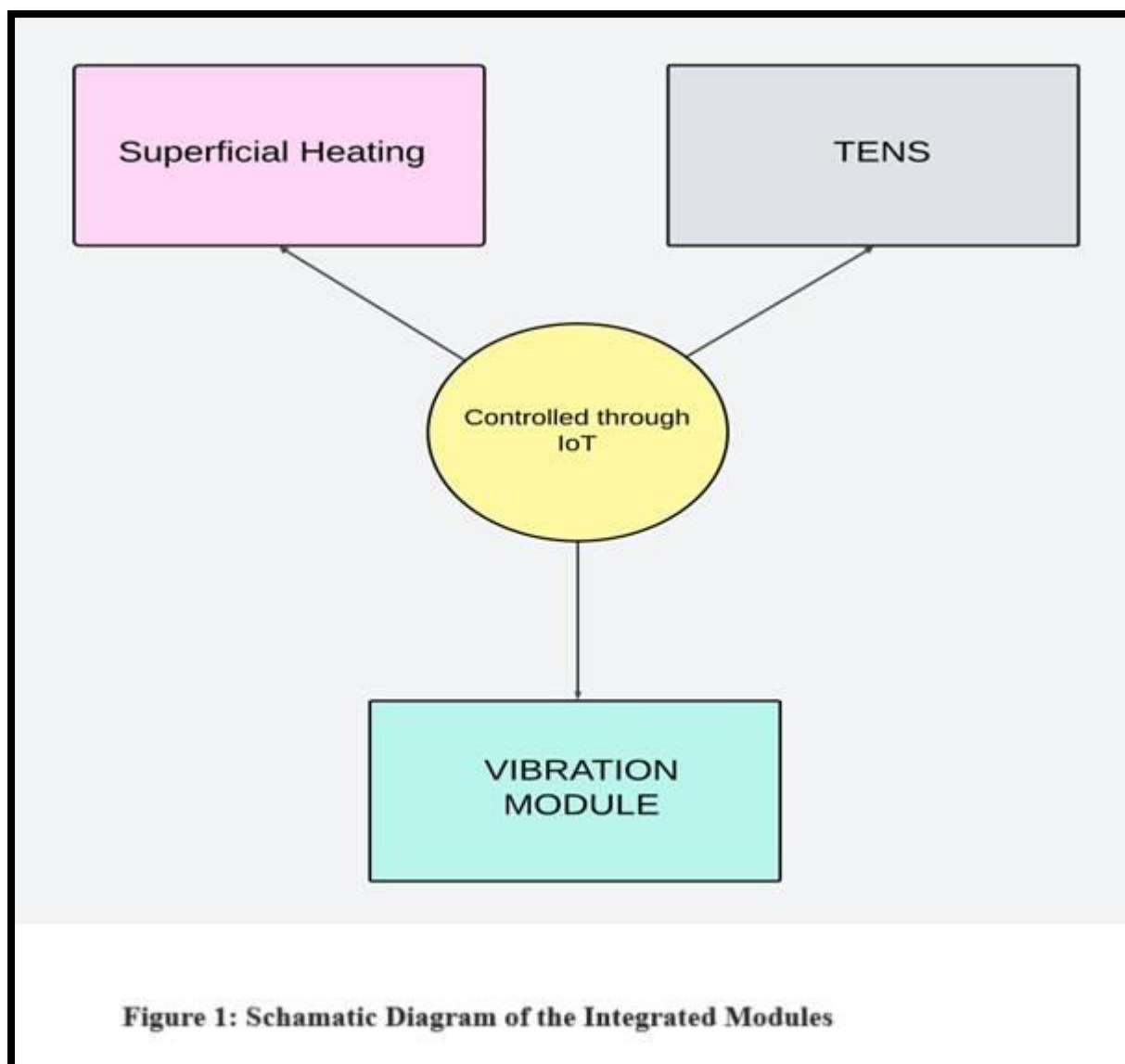

**Role of IoT:** Here's how IoT could enhance the effectiveness and convenience of PEMF and TENS therapy:

1. **Remote Monitoring and Adjustment:** IoT-enabled devices could track treatment sessions, monitor patient adherence, and collect data on pain levels and treatment outcomes [28]. Healthcare providers could remotely access this data to adjust treatment parameters or provide personalized recommendations, enhancing the efficacy of therapy [29].
2. **Personalized Treatment Plans:** By analyzing data collected from IoT-enabled devices, healthcare providers could develop personalized treatment plans tailored to each patient's needs. Machine learning algorithms could analyze patterns in patient data to optimize treatment parameters and predict future pain flare-ups, allowing for proactive intervention [30].
3. **Real-time Feedback and Alerts:** IoT devices could provide real-time feedback to patients, such as reminders to adhere to their treatment schedule or alerts if treatment parameters need adjustment. This real-time feedback can improve

patient engagement and compliance with therapy, leading to better pain management outcomes.

4. **Integration with Wearable Technology:** IoT-controlled PEMF and TENS devices could integrate with wearable technology, such as smartwatches or fitness trackers, to provide seamless monitoring of patient health metrics and activity levels. This comprehensive data can provide valuable insights into the factors influencing pain levels and treatment effectiveness.
5. **Telemedicine Integration:** IoT-enabled pain management devices could integrate with telemedicine platforms, allowing patients to consult with healthcare providers remotely and receive personalized guidance and support. Telemedicine appointments can also facilitate ongoing monitoring of treatment progress and adjustments as needed.

**Proposed model:**As shown in Figure 2, the proposed model can deliver Superficial Heating Modalities (SHM), Ultra Sound Therapy (UST), or Transcutaneous Electric Nerve Stimulation (TENS) alternately or simultaneously. Healthcare professionals could control the mode of operation from the remote end.

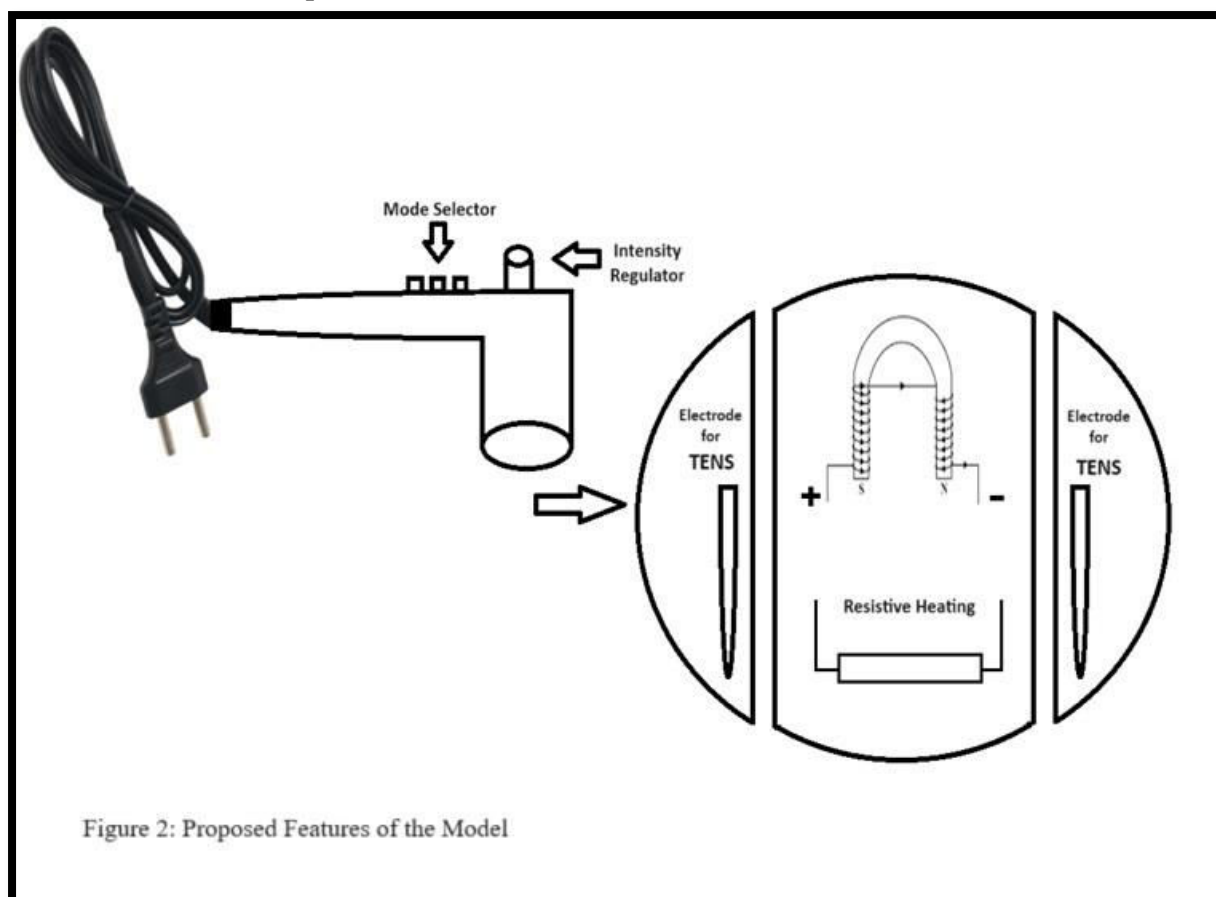

Figure 2: Proposed Features of the Model

**Components:** The proposed model consists of three main components: a heating element for SHM, a PEMF generator, and electrodes for TENS. These components are integrated into a single device controlled by a microcontroller unit (MCU). The MCU is

connected to a remote control interface, allowing healthcare professionals to adjust therapy parameters such as intensity, duration, and mode of operation.

Modes of Operation: The system operates in three main modes:

1. **Superficial Heating Modality (SHM) Mode:** In this mode, the heating element is activated to provide localized heat therapy to the target area. The temperature and duration of heating can be adjusted remotely to achieve the desired therapeutic effect. The temperature range for SHM is 70 to 75°C [11]. The following circuit in Figure 3 generates heat very simply and without using any DC supply. This makes the unit very simple and lightweight. Maximum heat is generated at position 1 of the rotary switch. Heat generation can be reduced by changing the position of the switch to 3 and 4 respectively [12].

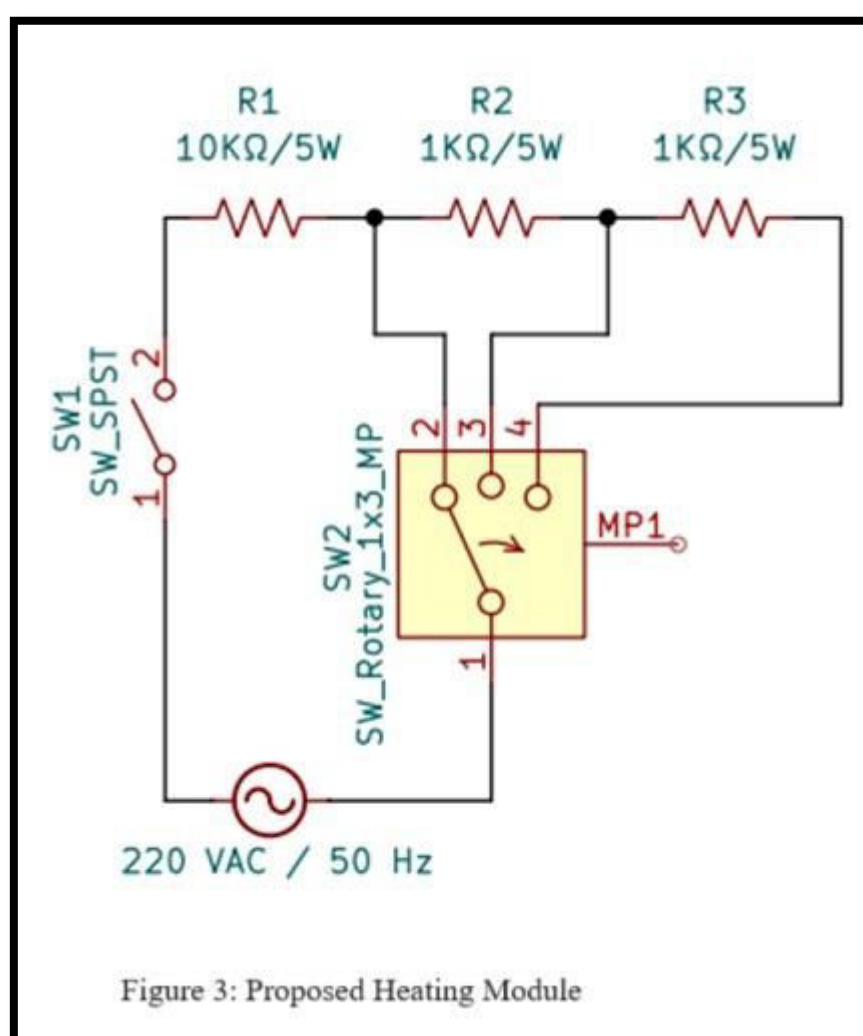

2. **Vibration Therapy:** The vibration device generates mechanical oscillations at a frequency of 50 Hz. This means it produces 50 cycles of vibration per second. These oscillations are transferred to the body tissues when the device is applied to specific areas. The rapid oscillations stimulate muscle spindles, which are sensory receptors within the muscle that detect changes in muscle length and

speed. This stimulation leads to a reflexive muscle contraction known as the tonic vibration reflex (TVR). The TVR helps in enhancing muscle tone and strength by repeatedly contracting and relaxing the muscles [15].

In Figure 4, the primary side of the transformer, a ferromagnetic plate has been mounted to create the desired vibration. A small magnet is mounted on the top of the plate to provide the necessary damping. The vibration frequency is the same as that of the frequency of the input to the primary which is 50 Hz in India. For the vibration module there is no need for the secondary part of the transformer. The secondary part is to provide the necessary supply for TENS. 3. Transcutaneous Electrical Nerve Stimulation (TENS) Mode: In this mode, the electrodes deliver electrical stimulation to the nerves, modulating pain signals and promoting muscle relaxation. The frequency, intensity, and pulse duration of the electrical stimulation can be adjusted remotely for optimal pain relief. Low-Frequency TENS uses 1-10 Hz, often used for chronic pain relief and muscle stimulation, while High-Frequency TENS uses 50-150 Hz, commonly used for acute pain relief [2]. Current levels range from 0-10 mA for gentle stimulation and initial treatments, 10-50 mA for moderate-intensity TENS, and 50-100 mA for high-intensity TENS used under professional supervision [5]. In the proposed model for simplification 50 Hz supply has been used with the option of changing voltages to change the current up to the desired level [7].

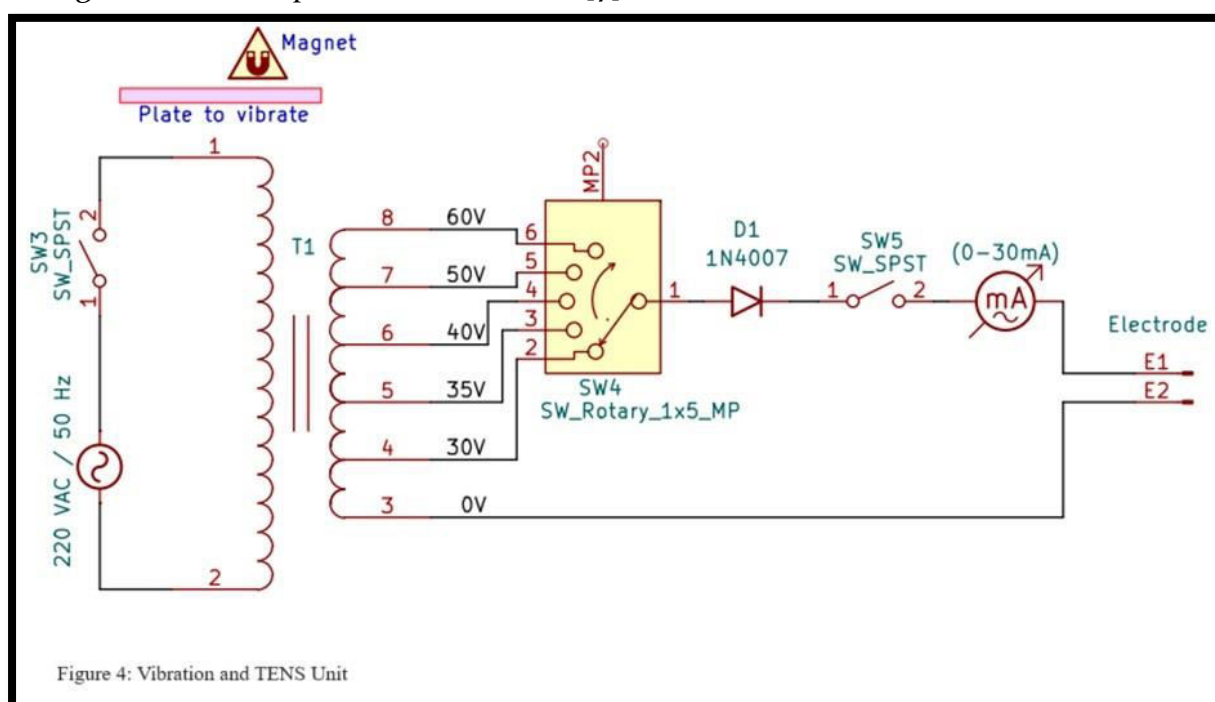

**Combined Mode:** Additionally, the system supports a Combined Mode, where two or all three modalities can be delivered simultaneously or in sequence. This flexibility allows healthcare professionals to tailor therapy sessions to each patient's specific needs and condition [19].

**Clinical Applications:** The proposed integrated therapy system has numerous potential clinical applications across various medical specialties, including rehabilitation medicine, orthopedics, sports medicine, and pain management. By providing remote control functionality, healthcare professionals can monitor and adjust therapy parameters in real-time, optimizing treatment outcomes and improving patient satisfaction [27].

**Result:** The system has been tested for three modes separately and/ or in combined mode by controlling the switch position from the remote end through the Internet(IoT). First, the switch positions were controlled as shown in Table 1. This table describes the operational modes of a device controlled by five switches (SW<sub>1</sub> to SW<sub>5</sub>). Each mode corresponds to a specific combination of switch states, determining the behaviour of the device's heater and TENS (Transcutaneous Electrical Nerve Stimulation) functionalities. Here's a detailed explanation of each mode:

	SW <sub>1</sub>	SW <sub>2</sub>	SW <sub>3</sub>	SW <sub>4</sub>	SW <sub>5</sub>	Mode
1	ON	2	OFF	X	OFF	Heater Highest
2	ON	3	OFF	X	OFF	Heater Moderate
3	ON	4	OFF	X	OFF	Heater Minimum
4	OFF	X	ON	X	OFF	Vibrator ON, TENS OFF
5	OFF	X	ON	2	ON	Vibrator ON (Unused), TENS ON with Lowest Current
6	OFF	X	ON	3, 4, 5	ON	Vibrator ON (Unused), TENS ON with Moderate Current
7	OFF	X	ON	6	ON	Vibrator ON (Unused), TENS ON with Highest Current

Table 1: Switch positions to control different modes.

**Heater performance:** The heater performance is recorded in the following table. The temperature at the face of the heater when exposed to normal air is shown in Table 2, which is also shown in the attached graph of Figure 5.



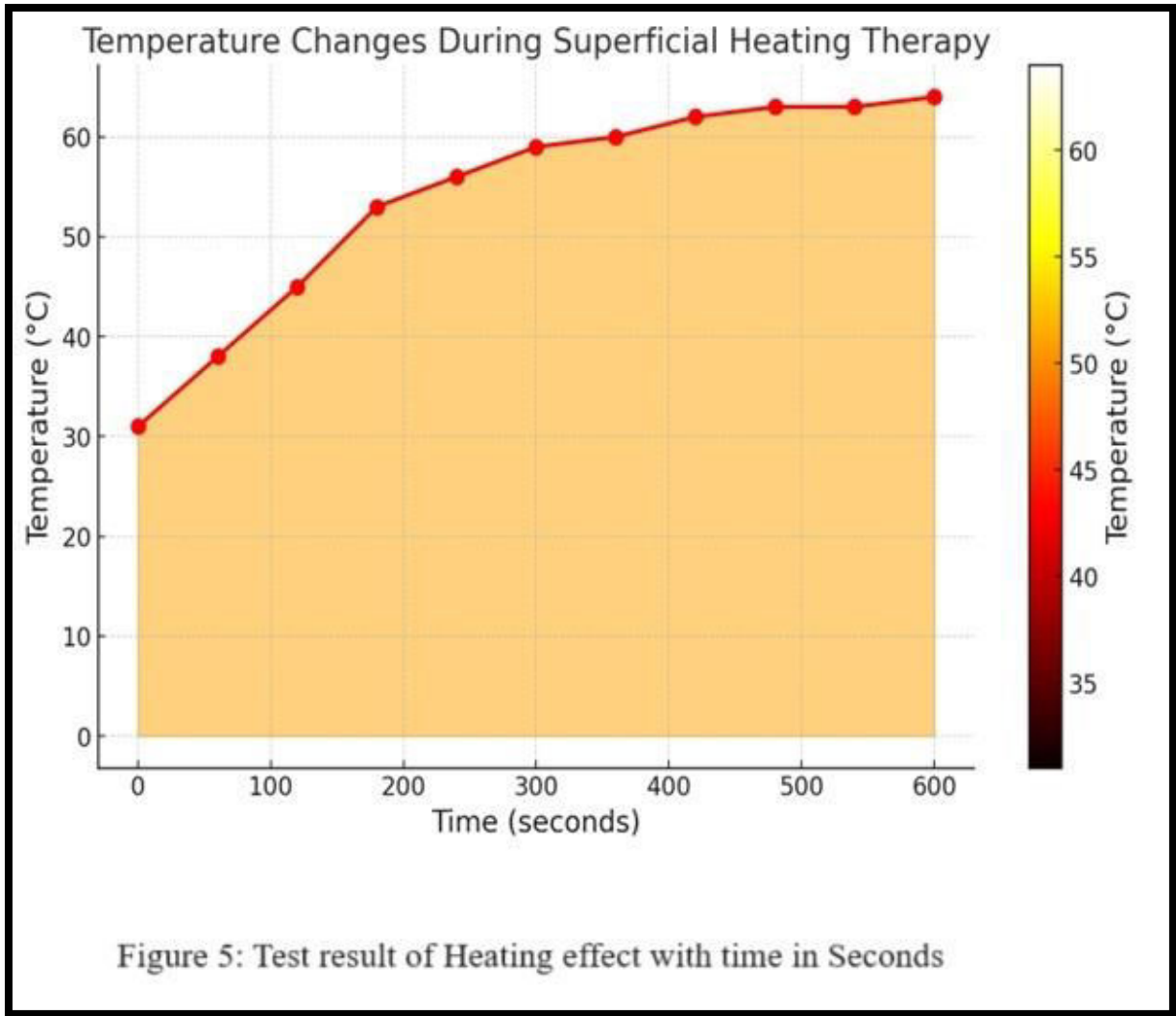

Sl. No.	Time	Temperature
1	0	31
2	60	38
3	120	45
4	180	53
5	240	56
6	300	59
7	360	60
8	420	62
9	480	63
10	540	63
11	600	64

Table 2: Temperature measured for a period of 600s



**Vibrator Performance:**

The vibration was tested for 10 minutes under moderate pressure, producing very little heat or noise.

**TENS Performance:**

The TENS unit has been tested by mimicking the human body as per the electrical equivalent circuit as achieved by Chizmadzhev YA et al [31]. The current rating has been tested on the Chizmadzhev model as follows in Figure 6. The recorded current has been tabulated in Table 3.

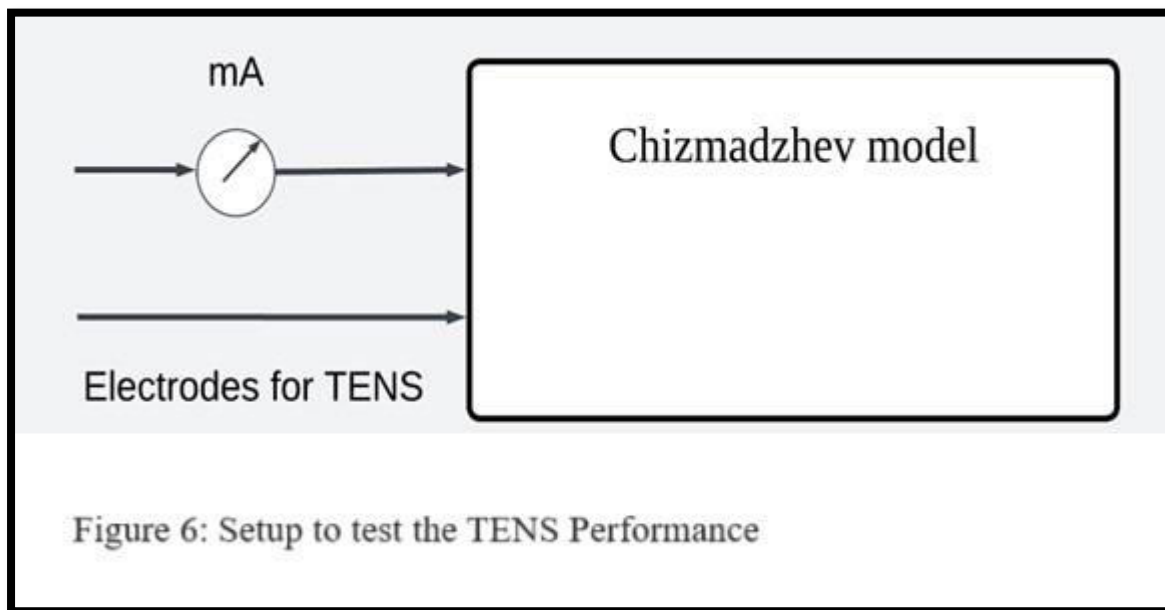

Figure 6: Setup to test the TENS Performance

Sl. No.	Voltage	Current (mA) recorded after 1 mS	Remarks
1	30	3	Underrated current
2	35	6	Underrated current
3	40	10	Desired current in normal tissue
4	50	18	May be used for actual use
5	60	26	May be used for actual use

Table 3: V-I relationship of TENS unit

**Features:**

The Main Features of the device can be listed as\_

- Light Weight: Excluding Electrodes, it weighs 420 gms.
- Selective Use: Selective use reduce Power consumption,
- Integration: Integration of three different technologies of Pain management, in a single device would make the device highly useful.

- Low Cost: Use of a very small number of components keeps the cost of the device minimum.

**Conclusion:** The integration of IoT-controlled Vibrators, Superficial Heating Modalities (SHM), and Transcutaneous Electrical Nerve Stimulation (TENS) represents a significant advancement in the field of pain management. This multifaceted approach combines the benefits of various therapeutic modalities to provide a comprehensive and individualized treatment plan for patients suffering from chronic pain and musculoskeletal conditions.

The proposed model, with its remote monitoring and adjustment capabilities, personalized treatment plans, real-time feedback, and integration with wearable technology, offers a promising solution for enhancing the efficacy and convenience of pain management therapies. By leveraging the power of IoT, healthcare providers can offer more precise and adaptive treatments, ensuring optimal therapeutic outcomes and improved patient satisfaction.

The combination of Vibrator, SHM, and TENS allows for targeted pain relief and enhanced tissue healing, addressing both superficial and deep-seated pain sources. The flexibility to deliver these therapies alternately or simultaneously provides a tailored approach that can be adjusted to meet the unique needs of each patient.

Future research should focus on further refining this integrated system, exploring its applications across different medical specialties, and conducting clinical trials to validate its effectiveness. Additionally, the ongoing development of machine learning algorithms to analyze patient data and optimize treatment parameters will be crucial in advancing this technology.

In conclusion, the IoT-controlled integrated therapy system holds great potential to revolutionize pain management by providing a holistic, adaptive, and patient-centric approach. This innovation not only enhances the quality of care but also empowers patients to actively participate in their treatment, ultimately leading to better health outcomes and improved quality of life.

#### References:

1. Tong J, Chen Z, Sun G, Zhou J, Zeng Y, Zhong P, Deng C, Chen X, Liu L, Wang S, Chen J, Liao Y. The Efficacy of Pulsed Electromagnetic Fields on Pain, Stiffness, and Physical Function in Osteoarthritis: A Systematic Review and Meta-Analysis. *Pain Res Manag.* 2022 May 9;2022:9939891. PMID: 35586276; PMCID: PMC9110240.
2. Zanoli, G.; Albarova-Corral, I.; Ancona, M.; Grattagliano, I.; Hotfiel, T.; Iolascon, G.; Krüger, K.; Rodríguez Maruri, G. Current Indications and Future Direction in Heat Therapy for Musculoskeletal Pain: A Narrative Review. *Muscles* 2024, 3, 212-223.

3. Markovic L, Wagner B, Crevenna R. Effects of pulsed electromagnetic field therapy on outcomes associated with osteoarthritis : A systematic review of systematic reviews. *Wien Klin Wochenschr.* 2022 Jun;134(11-12):425-433. Epub 2022 Apr 1. PMID: 35362792; PMCID: PMC9213303.
4. Liu L, Huang B, Lu Y, Zhao Y, Tang X, Shi Y. Interactions between electromagnetic radiation and biological systems. *iScience.* 2024 Feb 10;27(3):109201. PMID: 38433903; PMCID: PMC10906530.
5. Johnson, M.I. Resolving Long-Standing Uncertainty about the Clinical Efficacy of Transcutaneous Electrical Nerve Stimulation (TENS) to Relieve Pain: A Comprehensive Review of Factors Influencing Outcome. *Medicina* 2021, 57, 378.
6. Johnson M. Transcutaneous Electrical Nerve Stimulation: Mechanisms, Clinical Application and Evidence. *Rev Pain.* 2007 Aug;1(1):7-11. PMID: 26526976; PMCID: PMC4589923.
7. Vance, C.G.T.; Dailey, D.L.; Chimenti, R.L.; Van Gorp, B.J.; Crofford, L.J.; Sluka, K.A. Using TENS for Pain Control: Update on the State of the Evidence. *Medicina* 2022, 58, 1332.
8. Ventriglia G, Gervasoni F, Franco M, Magni A, Panico G, Iolascon G. Musculoskeletal Pain Management and Thermotherapy: An Exploratory Analysis of Italian Physicians' Attitude, Beliefs, and Prescribing Habits. *J Pain Res.* 2023 May 11;16:1547-1557. PMID: 37197390; PMCID: PMC10184851.
9. Vance, C.G.T.; Dailey, D.L.; Chimenti, R.L.; Van Gorp, B.J.; Crofford, L.J.; Sluka, K.A. Using TENS for Pain Control: Update on the State of the Evidence. *Medicina* 2022, 58, 1332.
10. Claudia A Knight, Carrie R Rutledge, Michael E Cox, Martha Acosta, Susan J Hall, Effect of Superficial Heat, Deep Heat, and Active Exercise Warm-up on the Extensibility of the Plantar Flexors, *Physical Therapy*, Volume 81, Issue 6, 1 June 2001, Pages 1206–1214,
11. Malanga, G. A., Yan, N., & Stark, J. (2014). Mechanisms and efficacy of heat and cold therapies for musculoskeletal injury. *Postgraduate Medicine*, 127(1), 57–65.
12. Tseng, S.-Y.; Lai, C.-L.; Ko, C.-P.; Chang, Y.-K.; Fan, H.-C.; Wang, C.-H. The Effectiveness of Whole-Body Vibration and Heat Therapy on the Muscle Strength, Flexibility, and Balance Abilities of Elderly Groups. *Int. J. Environ. Res. Public Health* 2023, 20, 1650.
13. Lin-Rong Liao, Meizhen Huang, Freddy M.H. Lam, Marco Y.C. Pang, Effects of Whole-Body Vibration Therapy on Body Functions and Structures, Activity, and Participation Poststroke: A Systematic Review, *Physical Therapy*, Volume 94, Issue 9, 1 September 2014, Pages 1232–1251.
14. Wang, J., et al. "The effect of whole body vibration on fracture healing-a systematic review." *Eur Cell Mater* 34 (2017): 108-127.

15. Savage, R., Billing, D., Furnell, A. et al. Whole-body vibration and occupational physical performance: a review. *Int Arch Occup Environ Health* **89**, 181–197 (2016).
16. Pilch W, Czerwińska-Ledwig O, Chitryniewicz-Rostek J, Nastalek M, Kręzałek P, Jędrychowska D, Totko-Borkusewicz N, Uher I, Kaško D, Tota Ł, Tyka A, Tyka A, Piotrowska A. The Impact of Vibration Therapy Interventions on Skin Condition and Skin Temperature Changes in Young Women with Lipodystrophy: A Pilot Study. *Evid Based Complement Alternat Med*. 2019 May 29;2019:8436325. PMID: 31275423; PMCID: PMC6560364.
17. Vance CG, Dailey DL, Rakel BA, Sluka KA. Using TENS for pain control: the state of the evidence. *Pain Manag*. 2014 May;4(3):197-209. PMID: 24953072; PMCID: PMC4186747.
18. Eid MM, Hamed NS, Abdelbasset WK, Elkholi SM, Eladl HM, Bahey El-Deen HA. A comparative study between transcutaneous electrical nerve stimulation and pulsed electromagnetic field therapy in the management of post-herpetic neuralgia of the sciatic nerve. *Medicine (Baltimore)*. 2022 Nov 4;101(44):e31433. PMID: 36343068; PMCID: PMC9646515.
19. Waldorff EI, Zhang N, Ryaby JT. Pulsed electromagnetic field applications: A corporate perspective. *J OrthopTranslat*. 2017 Mar 31;9:60-68. PMID: 29662800; PMCID: PMC5822965.
20. Somaa, Fahad A., Tom A. de Graaf, and Alexander T. Sack. "Transcranial magnetic stimulation in the treatment of neurological diseases." *Frontiers in Neurology* 13 (2022): 793253.
21. Paolucci T, Pezzi L, Centra AM, Giannandrea N, Bellomo RG, Saggini R. Electromagnetic Field Therapy: A Rehabilitative Perspective in the Management of Musculoskeletal Pain - A Systematic Review. *J Pain Res*. 2020 Jun 12;13:1385-1400. PMID: 32606905; PMCID: PMC7297361.
22. Khooshideh, Maryam MD\*; Latifi Rostami, Seyedeh Sakineh MD\*; Sheikh, Mahdi MD, PhD†; Ghorbani Yekta, Batool MD‡; Shahriari, Ali MD§. Pulsed Electromagnetic Fields for Postsurgical Pain Management in Women Undergoing Cesarean Section: A Randomized, Double-Blind, Placebo-controlled Trial. *The Clinical Journal of Pain* 33(2):p 142-147, February 2017. |
23. Basford JR. A historical perspective of the popular use of electric and magnetic therapy. *Arch Phys Med Rehabil*. 2001 Sep;82(9):1261-9. PMID: 11552201.
24. Bren KL, Eisenberg R, Gray HB. Discovery of the magnetic behavior of hemoglobin: A beginning of bioinorganic chemistry. *Proc Natl Acad Sci U S A*. 2015 Oct 27;112(43):13123-7. PMID: 26508205; PMCID: PMC4629386.
25. Vance CGT, Dailey DL, Chimenti RL, Van Gorp BJ, Crofford LJ, Sluka KA. Using TENS for Pain Control: Update on the State of the Evidence. *Medicina (Kaunas)*. 2022 Sep 22;58(10):1332. PMID: 36295493; PMCID: PMC9611192.

26. R. S. Hassan and Y. Lee, "Passive Wireless Sensor Utilizing an Interdigital Capacitor for Ongoing Monitoring of Glucose Concentration," 2023 45th Annual International Conference of the IEEE Engineering in Medicine & Biology Society (EMBC), Sydney, Australia, 2023, pp. 1-4.
27. N. Krishna, V. A. Ashrita Dikshit and B. Rakshit Preran, "TENSify: A Therapeutic approach towards Myotonia Congenita," 2024 4th International Conference on Data Engineering and Communication Systems (ICDECS), Bangalore, India, 2024, pp. 1-5.
28. Argüello Prada, Erick Javier. 2020. "The Internet of Things (IoT) in Pain Assessment and Management: An Overview." *Informatics in Medicine Unlocked* 18: 100298.
29. Dang A, Arora D, Rane P. Role of digital therapeutics and the changing future of healthcare. *J Family Med Prim Care*. 2020 May 31;9(5):2207-2213. PMID: 32754475; PMCID: PMC7380804.
30. Jagatheesaperumal, S.K.; Rajkumar, S.; Suresh, J.V.; Gumaiei, A.H.; Alhakbani, N.; Uddin, M.Z.; Hassan, M.M. An IoT-Based Framework for Personalized Health Assessment and Recommendations Using Machine Learning. *Mathematics* 2023, 11, 2758.
31. Chizmadzhev YA, Indenbom AV, Kuzmin PI, Galichenko SV, Weaver JC, Potts RO. Electrical properties of skin at moderate voltages: contribution of appendageal macropores. *Biophys J*. 1998 Feb;74(2 Pt 1):843-56. PMID: 9533696; PMCID: PMC1302564.